



Intelligent Refractor  
**RT-5100**



THE ART OF EYE CARE

# RT Reliability and Technology -5100

Assured  
technology

page

2

Reliable  
usability

page

3

Advanced  
functions

page

4

Expanding  
possibilities

page

5

Experience the excellence with the RT-5100.

Do you know what "RT" stands for?

Originally meaning intelligent "refractor", it also stands for "Reliability and Technology."

A long-time seller, the RT-5100 incorporates our continuous quality improvement.



# Assured technology

## Ergonomic Design

The RT-5100 fulfills the operators' two dreams: sophisticated design and comfortable examination. Its stylish design perfectly fits in a small space, providing a quick and accurate exam for both operators and patients.

## Smooth, Speedy, Silent Lens Change

The RT-5100 offers quick and smooth lens changes, allowing the operator to show minute changes of prescription at the touch of a button.

## High-performance Color LCD Touch Screen

The color LCD touch screen displays a great deal of information, including near vision charts, refraction diagrams, and explanations of common pathologies.

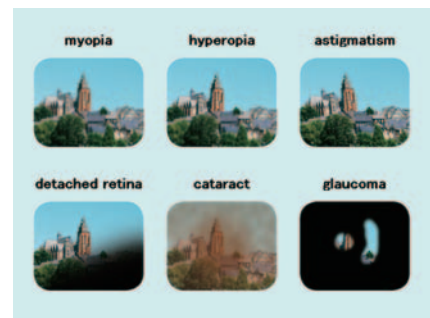
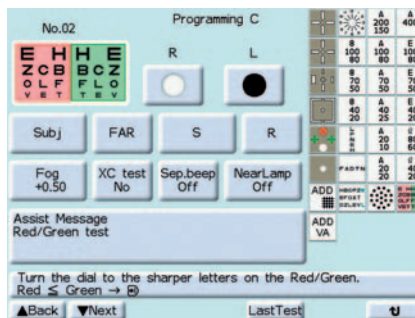
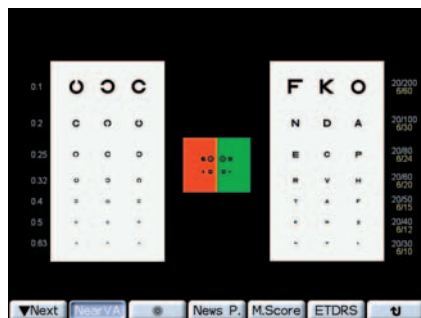

## Dial with S/C/A Mode Key

Applying ergonomic principals, the main control dial allows for rapid refractive value changes. The button in the center of the dial allows the operator to easily switch modes (S, C, and A) with one hand, while looking at a patient when performing retinoscopy or the refraction.



# Reliable usability

## Easy Programming and On-screen Assist Function

The RT-5100 offers easy programming of charts, cross cylinder test, and data fields (SPH, CYL, AXIS, and VA).

In addition, On-screen assist function guides the operator step-by-step through the entire process.

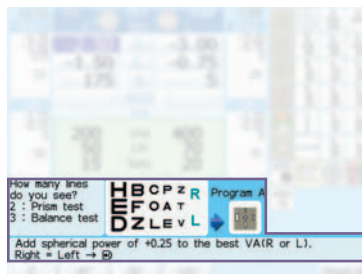

## Accurate Measurement

The RT-5100 forehead position detector incorporates a blue LED which turns off when the patient's forehead is in the correct position for measurement. Furthermore, the RT-5100 offers R/L independent PD adjustment and has visual field of 40 degrees, for more accurate measurement.



### Tiltable, Flip Display

The tiltable LCD screen achieves smooth operation in both sitting and standing positions. Moreover, when used for near testing, the displayed contents will be automatically flipped for the patient's easy view.



### for the Best Fit Prescription

The RT-5100 incorporates Final Fit, the adjusted power calculation program, to help find the most comfortable prescription for each patient.

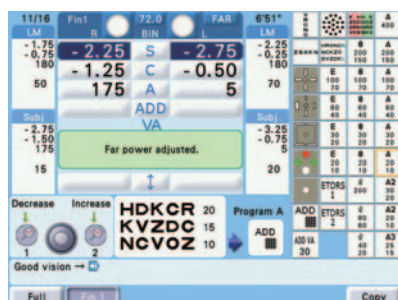

## Simple Maintenance

Maintenance is made simple by antifogging protective glasses, and detachable forehead rest / face shields.



# Advanced functions

## Clear Vision Range Check

Clear Vision Range Check supports a comprehensive explanation to patients. Based on measured values, it gives the patients a visual aid in a graphical form to demonstrate the range of clear vision with their correction in place.

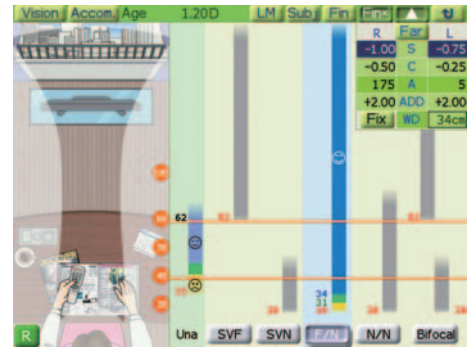

## Contrast and Reverse Functions

Contrast test is available when either the System Chart (SC) or Space Saving Chart (SSC)\*<sup>1</sup> is connected. The contrast function enables the testing of visual acuity under low-contrast conditions (25%, 12.5% and 6%). It helps the operator to evaluate the visual function using contrast sensitivity and to observe changes with time. In addition, the reverse function is also available, when connected with the SC. Reversed color VA chart is used for special test such as amblyopia.\*<sup>2</sup>

\*<sup>1</sup> Contrast test availability differs according to the type of SSC.

\*<sup>2</sup> VA value is for reference.

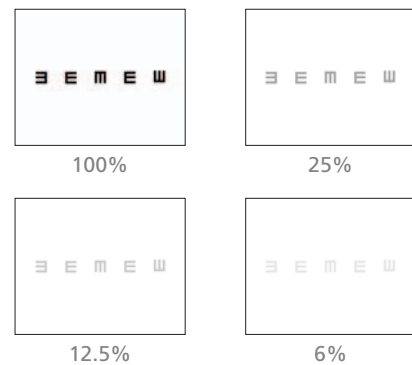

## Night Mode

Some patients have significantly different SPH, CYL and AXIS values between their day and night pupils. By touching the Night mode button on screen, it is possible to examine night-time visual acuity under low light condition. To measure in Night mode, a chart presenting device with Night measurement function\* is necessary.

\*The SSC-350, SSC-370, SC-1600 and SC-1600Pola

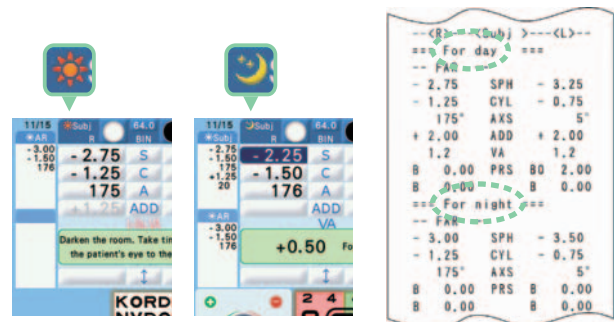

## 21-point Exams Plus Package (optional)

This optional software enables the operator to easily go through the process of the 21-point exams. These exams traditionally require the operator to have a deep knowledge of optics and many years of experience. This software guides the operator through the entire exams. Furthermore, after the measurement, the graph of visual function analysis and comparison with the Morgan standard are displayed.



# Expanding possibilities

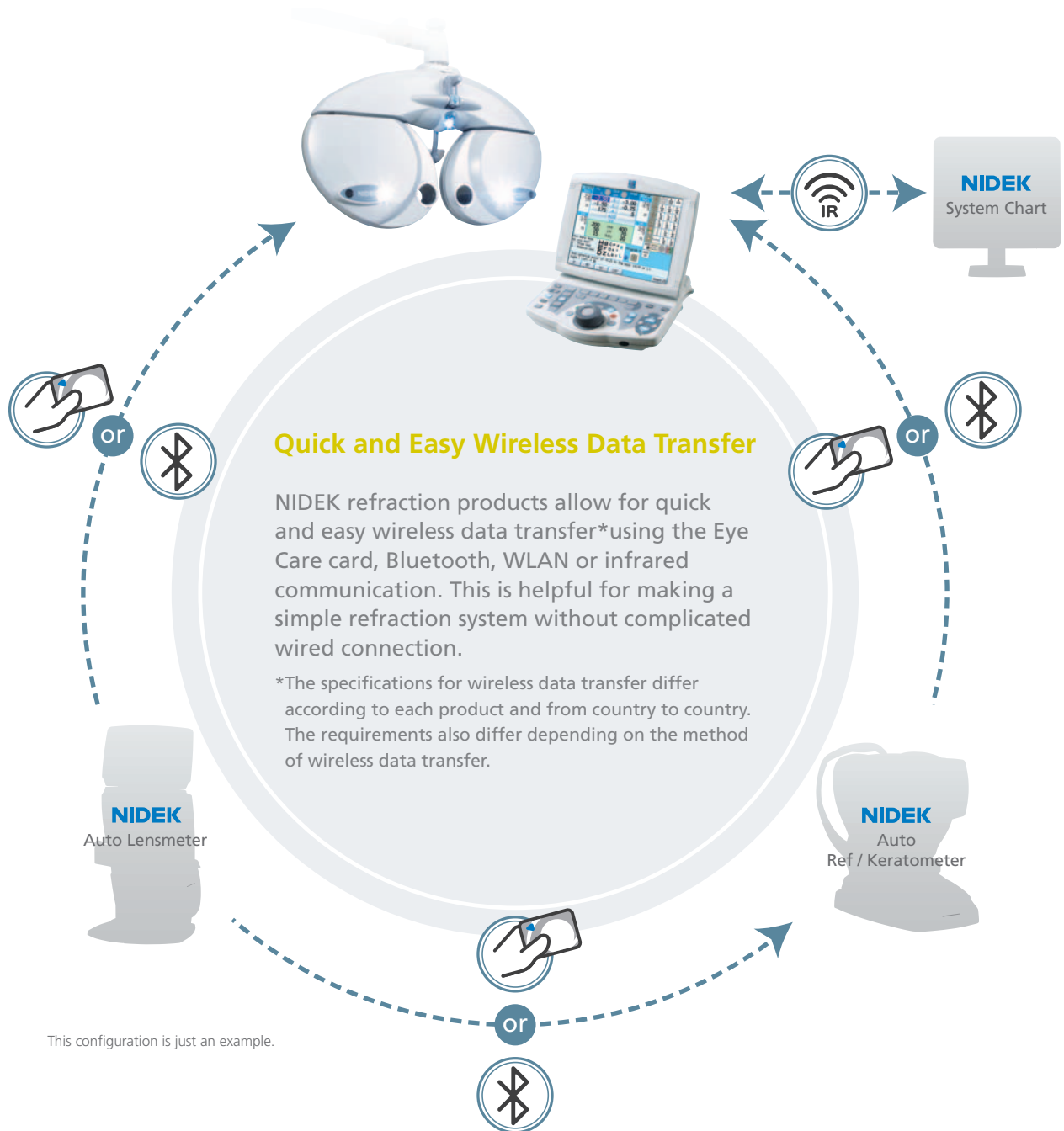

## Memory Box Connection

With NIDEK's Memory Box, it is possible to transfer data from one AR / ARK to multiple RT units.

## Daisy Chain Connection

Using the Daisy chain connection method, one AR / ARK can be connected to up to 5 RT units.

Please contact NIDEK for further information.

## COS-5100 Optometric Workstation

The COS-5100 Compact Optometric Workstation is here to fit each customer's needs. Below configuration is just an example. Please contact us for further information.

**RT-5100**  
Intelligent Refractor

**TONOREF III**  
Auto Ref / Kerato / Tono / Pachymeter

**SSC-370**  
Space Saving Chart

**ST-5100**  
Motorized Main Table & Side Table

**LM-1800PD / 1800P**  
Auto Lensmeter



### RT-5100S

The RT-5100 with stand is also available. Compact stand for control box incorporates a printer that provides easy loading.

## RT-5100 Specifications

Measurable range	
Sphere	-29.00 to +26.75 D (0.12 / 0.25 / 0.50 to 3.00 D increments) -19.00 to +16.75 D (cross cylinder test, prism test)
Cylinder	0.00 to ±8.75 D (0.25 / 1.00 / 2.00 / 3.00 D increments)
Axis	0 to 180° (1° / 5° / 15° increments)
PD	48 to 80 mm (far mode) 50 to 74 mm (near working distance of 35 cm) 54 to 80 mm (far PD possible for 100% convergence)
Prism	0 to 20Δ (0.1 / 0.5 / 2Δ increments)
Auxiliary lenses	
Cross cylinder lens	±0.25, ±0.50, ±0.25 D Auto-cross
Occluder	Available
Pinhole plate	ø2 mm
Red maddox rod	Right eye: horizontal, Left eye: vertical
Red / Green filter	Right eye: red, Left eye: green
PD check lens	Available
Polarizing filters	Right eye: 135° / Left eye: 45°, Right eye: 45° / Left eye: 135°
Fixed cross cylinder lens	±0.50 D (fixed with the Axis set at 90°)
Spherical lenses for retinoscope	+1.5 / +2.0 D
Dissociation prism	Right eye: 6ΔBU / Left eye: 10ΔBI, Right eye: 3ΔBD / Left eye: 3ΔBU
Dissociation prism for binocular balance*	Right eye: 3 to 10ΔBD / Left eye: 3 to 10ΔBU
Dissociation prism for horizontal phoria*	Right eye: 3 to 10ΔBU / Left eye: 3 to 10ΔBD
Dissociation prism for vertical phoria*	Right eye: 5 to 15ΔBI / Left eye: 5 to 15ΔBI
Fixed cross cylinder & dissociation prism for horizontal phoria*	Right eye: 3 to 10ΔBU / Left eye: 3 to 10ΔBD (only for 21-point Exams Plus Package)
Binocular open fog	Available
Visual field	40° (VD = 12 mm), 39° (VD = 13.75 mm)
Refraction distance for near vision	350 to 700 mm (50 mm increments)
Forehead rest adjustment	14 ±2 mm
Vertex distance marking	12, 14 (partially 13.75), 16, 18, 20 mm
Horizontal level adjustment	±2.5°
Display	8.4-inch color LCD
Printer	High speed line printer
Interface	RS-232C
Power supply	AC 100 to 240 V, 50 / 60 Hz
Power consumption	80 VA
Dimensions / Mass	
Refractor head	405 (W) x 102 (D) x 276 (H) mm / 3.5 kg 15.9 (W) x 4.0 (D) x 10.9 (H)" / 7.7 lbs.
Control box	220 (W) x 206 (D) x 200 (H) mm / 1.9 kg 8.7 (W) x 8.1 (D) x 7.9 (H)" / 4.2 lbs.
Relay box	194 (W) x 227 (D) x 72 (H) mm / 2.2 kg 7.6 (W) x 8.9 (D) x 2.8 (H)" / 4.9 lbs.
Printer	102 (W) x 86 (D) x 121 (H) mm / 0.3 kg 4.0 (W) x 3.4 (D) x 4.8 (H)" / 0.7 lbs.
Standard accessories	Near point chart, Near point rod, Forehead rest, Face shield, Stylus pen, Dust cover, Communication cable, Printer paper, Power cord, Ferrite core (for unit and stand type only)
Optional accessories	Mirror for examiner, Eye Care card (IC card), EyeCa-RW2, Memory Box, Contact cleaner, Plus Package, Infrared communication unit

\*changeable in increments of 0.5Δ for monocular measurement

### COS-5100 Table (ST-5100) Specifications

RT arm	Electromagnetic lock
Up-and-down of RT arm	Stroke 310 mm
Back-and-forth of RT arm	Stroke to patient side 230 mm
Power supply	AC 100 to 240 V, 50 / 60 Hz
Power consumption	600 VA (max, including RT and other optometry equipment)
Dimensions / Mass	
Motorized main table	Table top: 1025 (W) x 500 (D) x 680 to 860 (H) mm (stroke 180 mm) 40.4 (W) x 19.7 (D) x 26.8 to 33.9 (H)" (stroke 7.1")
Fixed side table	Table top: 1080 (W) x 723 (D) x 760 (H) mm 42.5 (W) x 28.5 (D) x 29.9 (H)"
Overall	1080 (W) x 1542 (D) x 1360 to 1850 (H) mm / 160 kg 42.5 (W) x 60.7 (D) x 61.2 to 72.8 (H)" / 352.7 lbs.

Product / Model name: Refractor RT-5100

All LCD images are simulated.

Brochure and listed features of the device are intended for non-US practitioners.

Specifications may vary depending on circumstances in each country.

Specifications and design are subject to change without notice.

## Dimensions (mm)

### RT-5100S

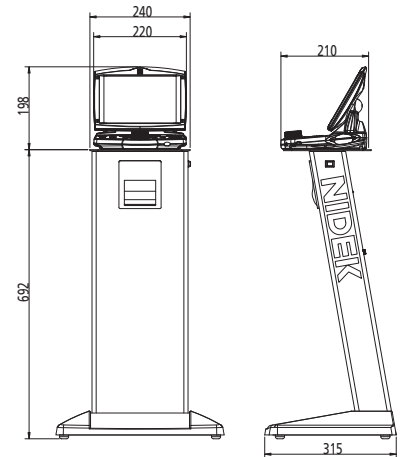

### COS-5100

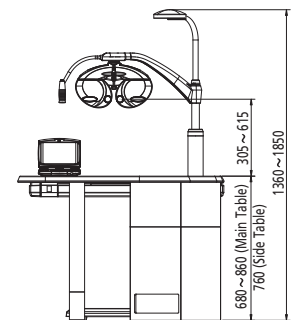
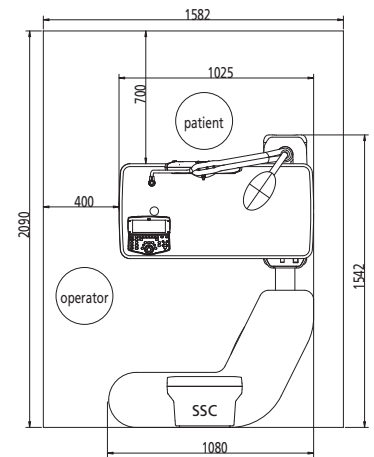

**HEAD OFFICE**  
(International Div.)  
34-14 Maehama, Hiroishi  
Gamagori, Aichi 443-0038,  
JAPAN  
TEL: +81-533-67-8895  
URL: <http://www.nidek.com>  
[Manufacturer]

**TOKYO OFFICE**  
(International Div.)  
3F Sumitomo Fudosan Hongo  
Bldg., 3-22-5 Hongo, Bunkyo-ku,  
Tokyo 113-0033, JAPAN  
TEL: +81-3-5844-2641  
URL: <http://www.nidek.com>

**NIDEK INC.**  
47651 Westinghouse Drive,  
Fremont, CA 94539, U.S.A.  
TEL: +1-510-226-5700  
+1-800-223-9044  
(US only)  
URL: <http://usa.nidek.com>

**NIDEK S.A.**  
Europarc,  
13 rue Auguste Perret,  
94042 Créteil, FRANCE  
TEL: +33-1-49 80 97 97  
URL: <http://www.nidek.fr>

**NIDEK TECHNOLOGIES S.R.L.**  
Via dell'Artigianato,  
6/A, 35020 Albignasego (Padova),  
ITALY  
TEL: +39 049 8629200/8626399  
URL: <http://www.nidektechnologies.it>

**NIDEK (SHANGHAI) CO., LTD.**  
Rm3205, Shanghai Multi  
Media Park, No.1027 Chang  
Ning Rd, Chang Ning District,  
Shanghai, CHINA 200050,  
TEL: +86 021-5212-7942  
URL: <http://www.nidek-china.cn>

**NIDEK SINGAPORE PTE. LTD.**  
51 Changi Business Park  
Central 2, #06-14, The  
Signature 486066,  
SINGAPORE  
TEL: +65 6588 0389